

LED Emergency Luminaries



LED Twin Spot Surface Mount Emergency Light

Surface Mounted Model: **SLEL-04**

SPECIFICATION	
Model No.	SLEL-04
Installation Mode	Back
Luminaries Type	Non-Maintained Type
Light Source	2 x 1W High Quality LED chips
Housing	Powder-coated Mild Steel
Input Voltage	AC 180V~242V, 50Hz
Rechargeable Battery	NiCd 12V 600mAh
Total Power Consumption	2W
Battery Recharge Duration	≤ 12 hours
Emergency Duration	≥ 3 Hours
Protection Rating	IP20
Insulation Class	Class one Earthing
Operation Temperature	0°C~50°C
LED Operating Life	≥ 50000 Hours
Battery Charge and Discharge Life Span	Approx. 4 year
Outside Features	"Red" "Yellow" "Green" indication light & "Test" switch
Test Button	Press type
LED "On" Indicator	"Red" "LED Mains On, "Green" LED Charging, "Yellow" LED Fault
Testing Standard	HKFSD Codes of Practice for minimum service installations and equipments *FSD PPA 104(A) (4th Revision) *BSEN 60598-2-22:2008, *BS 5266-1:2012



DIMENSION (mm) BOX : L266.3 x H161.5 x W46 mm, LIGHT HEAD: D100 mm

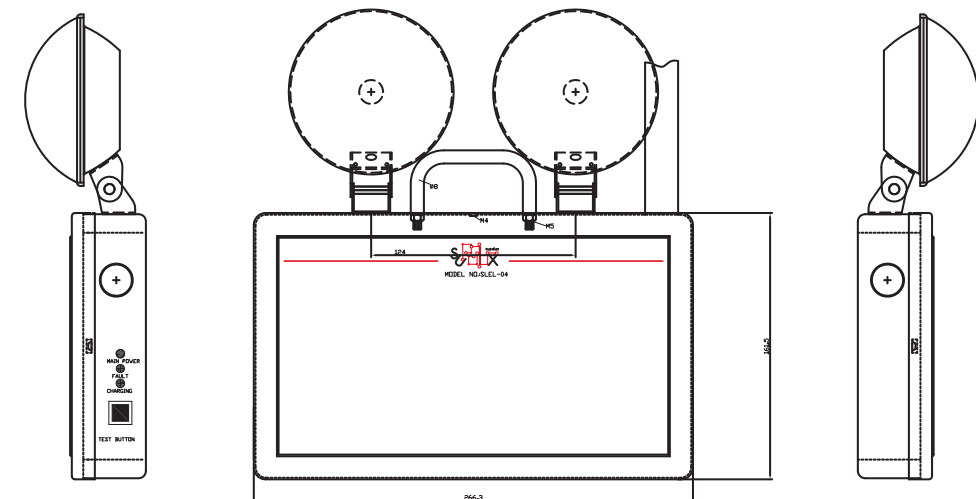

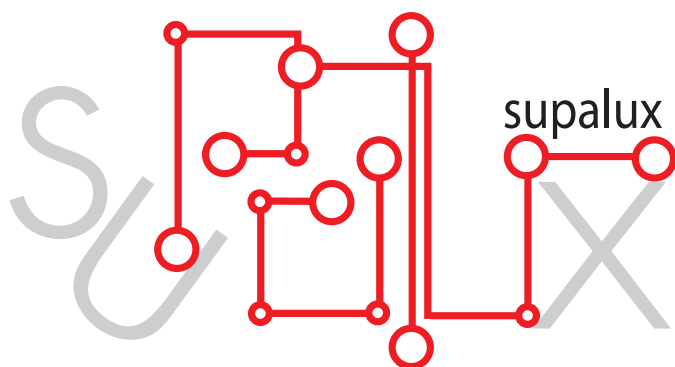

Web Site

<http://www.sl-led-application.com>

E-mail

info@sl-led-application.com

Tel

852 – 2370 9394

Fax

852 – 2743 1123

Address

Unit 202A, 20/F., Tak King Industrial Building,
27 Cheung Lee Street, Chai Wan, Hong Kong.

Editor

Au Pui Man
(openopw@gmail.com)